

Read this instruction carefully. See hardware and furniture part list for guidance.  
 Be sure all parts are complete, before you assemble. Place all wooden furniture parts on a clean and flat soft surface to prevent from being scratched.  
 Follow the figure to start assembling.

**CAUTION :** 1. Do not FULLY - TIGHTEN the nuts or nuts bolts until they are ready for assembly.  
 2. Do not OVER - TIGHTEN the nuts or bolts to avoid causing damages to the thread.  
 3. Keep all hardware parts out of reach of children.

**NOTE :** THE LIST AND QUANTITY SHOWN ARE FOR 1 UNIT ASSEMBLY.

Tools needed : Screwdriver (not provided).

PART LIST		
ITEM	DESCRIPTION	QTY
A	HEADBOARD	1 PC
B	FOOTBOARD	1 PC
C	SIDE RAIL	2 PCS
D	CENTER RAIL	1 PC
E	CENTER SUPPORT LEG	3 PCS
F	CENTER SUPPORT	2 PCS
G	BED SLAT	24 PCS

HARDWARE LIST		
ITEM	DESCRIPTION	QTY
1	WOOD SCREW M4 x 20mm	2 PCS
2	WOOD SCREW M3.5 x 16mm	8 PCS
3	M5 ALLEN KEY (BALL SHAPE)	1 PC
4	BED SLAT SIDE FITTER	24 PCS
5	BED SLAT CENTER FITTER	12 PCS

## STEP 1

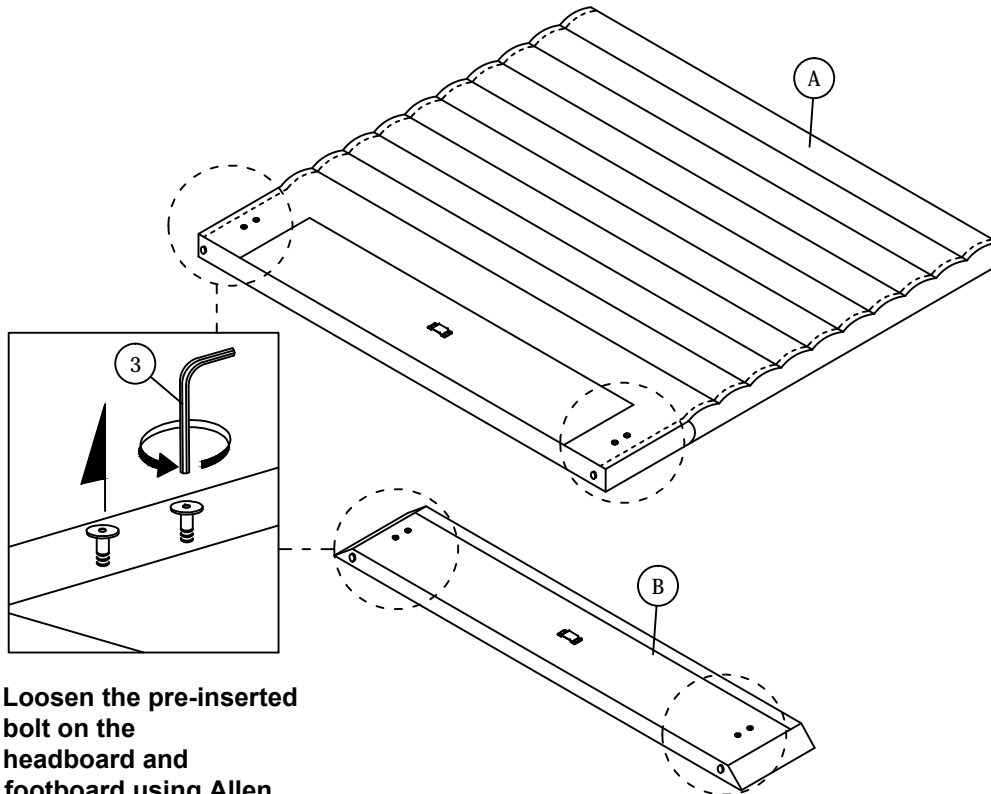

Loosen the pre-inserted bolt on the headboard and footboard using Allen key ball shape (3).

## STEP 2

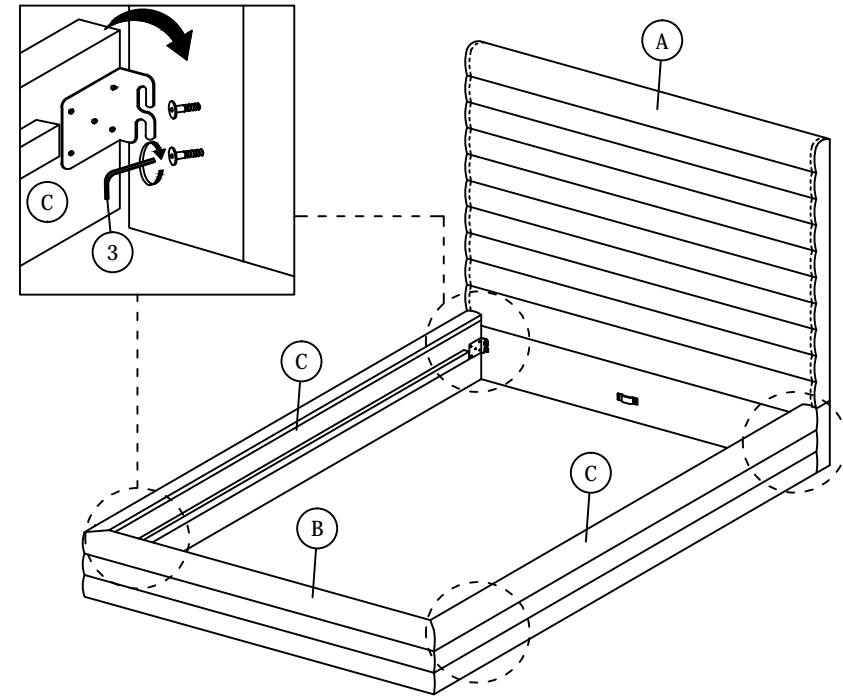

# ASSEMBLY INSTRUCTIONS

## STEP 3

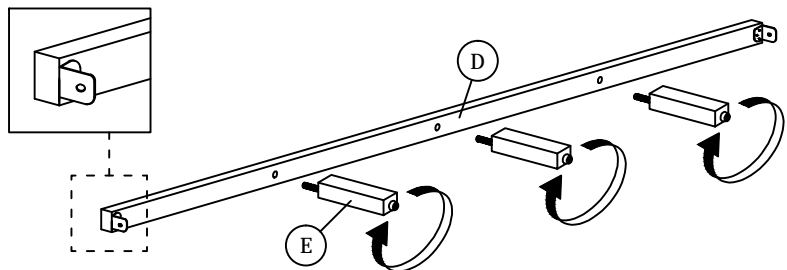

## STEP 4

### STEP 4.1

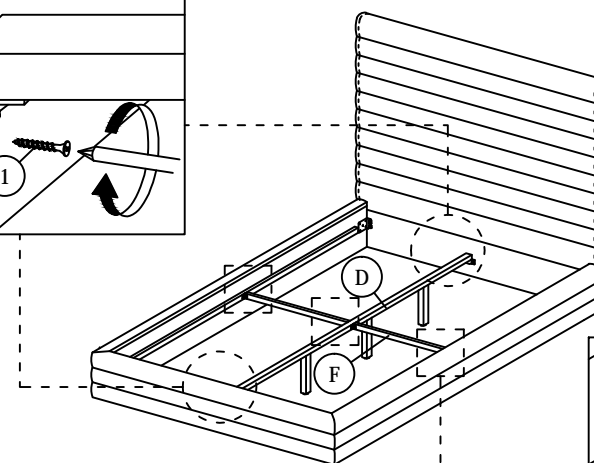
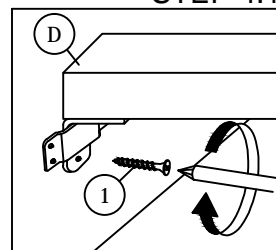

### STEP 4.2

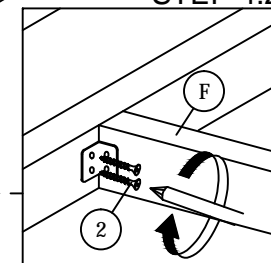

## STEP 5

### STEP 5.1

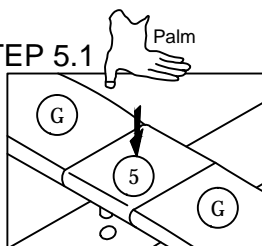

### STEP 5.2

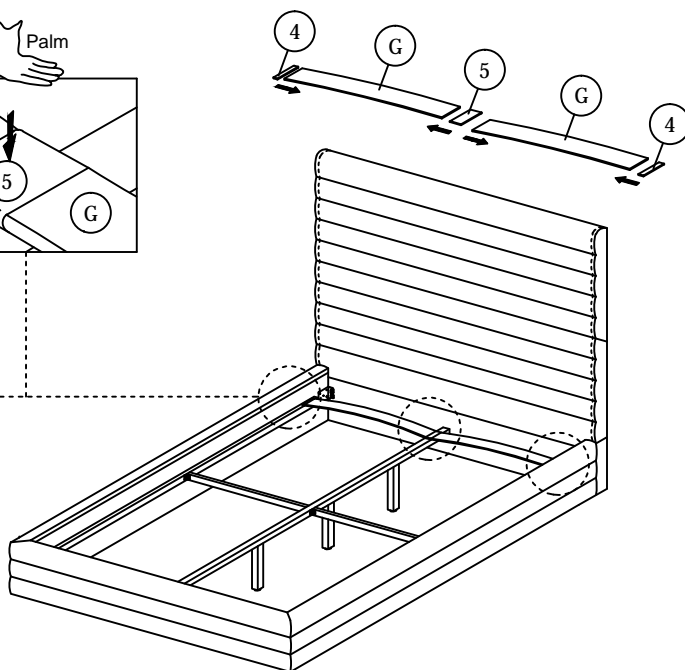
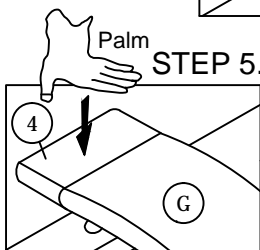

## STEP 6

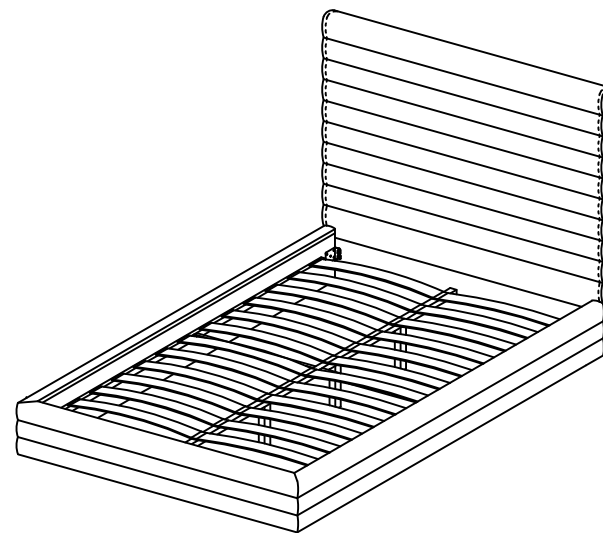

\* When moving the bed position, the center support legs must be adjust to be straight to avoid any broken problem.